

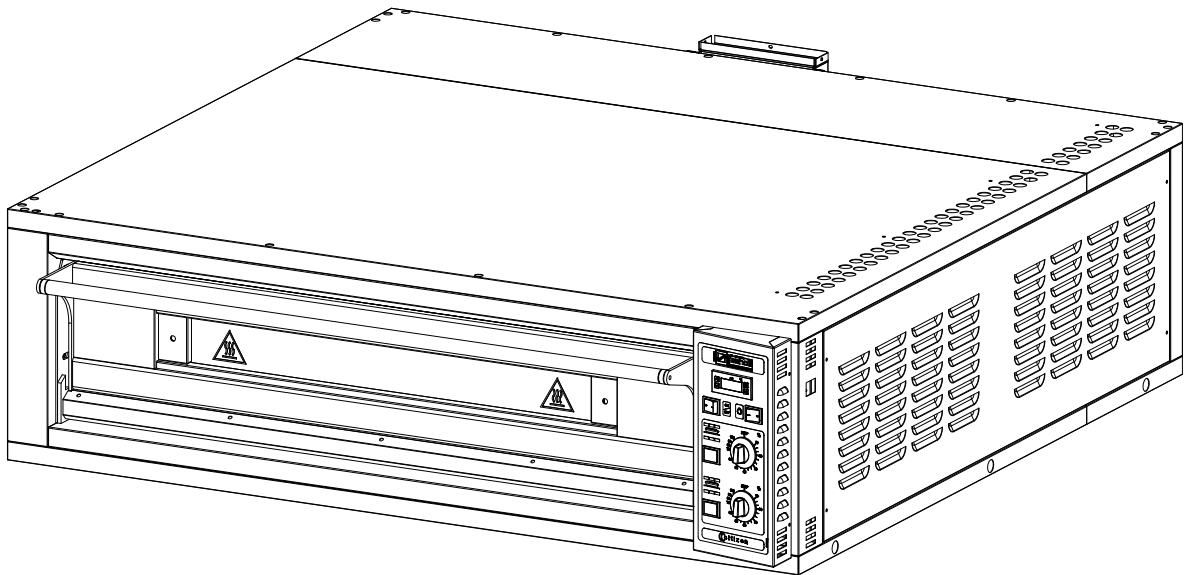

DR. ZANOLLI s.r.l.
Via Casa Quindici, 22
37060 Caselle di Sommacampagna (Verona) Italy
Tel +39 045 8581500 (r.a.)
Fax +39 045 8581455
Web: www.zanoli.it • e-mail: zanoli@zanoli.it



CITIZEN modular



Pizza and delicatessen ovens









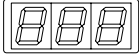

Installation, use and maintenance manual

dr.Zanoli s.r.l.
via Casa Quindici 22
37060 Caselle di Sommacampagna VR
Tel. +39-0458581500 Fax +39-0458581455
VAT N.IT00213620230

Citizen modular
manuale inglese
cod. CITM.E.EM.UK
rev. 0.3 del 20/03/07

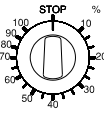
INDEX

1.INTRODUCTION	4
2.HOW TO USE THIS MANUAL.....	5
3.SPECIFICATIONS	7
3.1. PRODUCT IDENTIFICATION	7
3.2.CONFORMITY TO DIRECTIVES	7
3.3.ENVISAGED USE.....	7
3.4.TECHNICAL SPECIFICATIONS.....	8
4.INSTALLATION WARNINGS	9
4.1.DELIVERY CHECKS	9
4.2.CHOICE OF PLACE TO INSTALL THE OVEN	10
4.3.ELECTRICAL CONNECTION	10
5.INSTALLATION	12
5.1.CHECK LIST	12
5.2.CHOICE OF THE PLACE OF INSTALLATION OF THE OVEN	12
5.3.MOVING THE MODULE.....	12
5.4.MOUNTING THE MODULE	13
5.5.CONNECTING THE STEAM OUTLET	13
5.6.CHECKS BEFORE STARTING UP	14
6.WORKING	15
6.1 CONTROL PANEL.....	15
6.1.1.Temperature control.....	15
6.1.2.General.....	15
6.1.3.Power control	15
6.2.CONTROL DESCRIPTION	16
6.2.1.  Main ON/OFF switch	16
6.2.2.  Baking chamber light switch	16
6.2.3.  Light switch for suction hood	16
6.2.4. Temperature control  Baking chamber temperature display.....	16

6.2.5.		Set button		Push-button of ESC	17			
6.2.6.		and		buttons	17			
6.2.7.		OUT display				18		
6.2.8.		Power regulators				18		
6.2.9.		Oven roof	and		bedplate		pilot lamps	18
6.3.	ERROR DISPLAY					19		
6.3.1.	Short-circuited thermocouple					19		
6.3.2.	Disconnected thermocouple					19		
7.	USE					20		
7.1.	PREPARATION FOR USE					20		
7.2.	SWITCHING ON THE CONTROL PANEL					20		
7.3.	SETTING					20		
7.4.	STARTING BAKING					20		
7.5.	LOADING THE OVEN					21		
7.6.	GENERAL INDICATIONS FOR GOOD COOKING					21		
7.7.	SWITCHING OFF					22		
8.	CLEANING					23		
8.1.	CLEANING OF ANY VISIBLE GLASS AND STAINLESS STEEL PARTS					23		
8.2.	CLEANING OF ANY REFRACTORY PARTS					23		
8.3.	CLEANING THE OVEN'S BAKING CHAMBER					24		
8.4.	CLEANING THE EXTERNAL SURFACE					24		
9.	MAINTENANCE					25		
9.1.	ORDINARY MAINTENANCE WORK					25		
9.1.1.	Light replacement					25		
9.2.	ERROR DISPLAYS					26		
9.3.	ELECTRICAL DIAGRAM					26		
9.4.	ADJUSTMENT FOR DIFFERENT FEED VOLTAGES					26		
9.4.1.	Cabling of wires to the resistor					26		
9.4.2.	The cabling for the feed to the control panel					27		
9.4.3.	Attachment of new label					27		

INDEX

9.5.EXPLODED VIEWS AND SPARE PARTS LIST27

10.DECOMMISSIONING AND DEMOLITION37

1.INTRODUCTION

The modular “CITIZEN” ovens represent the new way of making traditional pizza ovens.

They are designed and manufactured to demanding mechanical and electrical standards and are built to last.

“CITIZEN” has been designed with the user in mind.

“CITIZEN” has a complete range to satisfy everybody’s needs.

dr.Zanolli S.r.l. thanks you for choosing one of our ovens. We at Zanolli can assure you that you have made a good choice as we have been making quality products for decades now and never engaged in counterproductive penny-pinching in our selection of the best available materials.

2.HOW TO USE THIS MANUAL

⚠ This manual should be kept near to the equipment itself so it can be quickly and easily consulted. The manual must travel with the equipment if it is moved to another owner as the latter may not be considered complete or safe without it.

Please take note of the code and revision numbers which are behind the back cover. If this copy should get mislaid or destroyed you can order another one by referring to the codes.

⚠ This manual is divided up into a number of chapters. All of these should be read by the installers, maintenance staff and the final user, both in relation to its **safe use** and in order to obtain the best result from this product.

Despite this we also give below some useful indications on how to look things up quickly in the various chapters.

⚠ **The paragraphs with this symbol contain essential safety information. They must all be read both by the installers and by the final user and any of his staff who may use the equipment. dr Zanolli S.r.l. shall not be held liable for any damage which may occur as a result of failure to observe the norms indicated in these paragraphs.**

⊗ The paragraphs with this symbol contain important information which can be used to avoid damage being caused to the equipment. It is the user's own interest also to read these paragraphs carefully.

Chapter 3 describes the field of use of the equipment and provides the characteristics and figures which may be needed when choosing, installing and using it. It should be used as a reference to check the use which is intended to be made of the equipment

corresponds to that for which it was designed, and whenever it is necessary to know an exact size value relating to the equipment.

Chapters 4 and for 5 provide all the information necessary for the installation of the equipment. The manual is primarily written for specialised staff but may be read in advance also by the final user to prepare and set up the space and plant necessary for the proper working of the equipment.

Chapters 6 is for reference whenever the user wishes to clarify specific aspects of the equipment operation. **It is not advisable to use these chapters as a way to learn how to use the equipment.**

Chapter 7 is useful for the user who has to learn to use the oven from scratch. It guides the user through the essential operations for switching on, use and switching off of the equipment in safety. To exploit all the possibilities of the equipment the user should refer to chapter 6.

Chapter 8 provides all the information required for the cleaning of the equipment i.e. all those operations which have to be carried out by the user in order to ensure that the equipment continues to function safely (especially from the point of view of hygiene) and generally obtains the best results at all times.

Chapter 9 provides the information necessary for proper periodic and extraordinary maintenance e.g. repairing or replacing of the equipment.

This chapter also has an exploded view of the equipment and list of spare parts to make ordering and replacing any damaged parts easier.

Chapter 10 provides the information necessary for the decommissioning and demolition.

 These maintenance operations must be carried out by specialised staff.

3.SPECIFICATIONS

3.1. Product identification

This is the manual for the following single deck from the Citizen series: CIT 6 Modular and CIT 9 Modular.

3.2.Conformity to directives

The following single deck:

CIT 6 Modular and CIT 9 Modular compulsory mark:



which guarantees their conformity to the following European directives:

89/336 CE electromagnetic compatibility

2006/95 CE low voltage

3.3.Envisaged use

The following single deck:

CIT 6 Modular and CIT 9 Modular have been designed to cook pizzas, similar products and pastry products, in pans or directly on refractory bedplates. The single deck CIT 6 Modular and CIT 9 Modular are intended for professional use in the catering sector (Restaurants, pizzerias, confectionery's shops, etc.) **and are exclusively intended to be used by qualified staff.**

The operations envisaged in normal usage are the opening and closing of the doors, the loading and unloading of the products from the bedplates of the baking chamber, switching on , regulation, switching off and cleaning of the equipment.

SPECIFICATIONS

3.4. Technical specifications

The following table shows the baking modules' technical specifications.

	CIT 6 Modular	CIT 9 Modular	Units of measur e-ment
Weight	160	204	Kg
External dimensions	1376×1025×411	1376×1376×411	mm
Cooking chamber size	1050×700×155	1050×1050×155	mm
Capacity (pizzas Ø30cm)	6	9	n°
Electrical feed	three-phase or three-phase + neutral		
Voltage	230 o 400		Vac
Frequency	50 o 60		Hz
Current at 400Vac 3-N 50/60Hz	13.9	16.55	A
Current at 230Vac 3 50/60Hz	24	28.6	A
Current at 230Vac 1-N 50/60Hz	38.3	48.7	A
Total electrical power	8.8	11.2	Kw
Electrical connection	plugless 4 or 5 lead cable		
Cooking chamber light			
Type	halogen		
Power	50		W
Cooking control			
Temperature control	electronic thermostat		
Maximum temperature which can be set	400		°C
Power control	separate for oven roof and bedplate		
Ambient conditions			
Temperature	0-40		°C
Maximum humidity	95% without condensation		

Table 3.1. Technical specifications

4.INSTALLATION WARNINGS

⚠ WARNING: These installation instructions are intended only for staff which is qualified for the installation and the maintenance of electrical and/or gas plants. Installation by any other person may cause damage to the equipment, persons, animals or things.

Furthermore in the place where you have to install the equipment, it is necessary to make any modifications or additions to the electrical and/or gas plant in the building in which the equipment is being installed, the person carrying out such alterations must obtain certification that the works have been carried out in accordance with the norms in force in that country.

4.1.Delivery checks

Unless otherwise agreed the products are carefully packed in a strong wooden crate with a blister sheet of nylon to protect them from shocks and humidity during transit and are delivered to the importer in the best possible condition.

We recommend, however, that the packaging is checked on arrival to ensure that there are no visible signs of damage. If there are any such signs indicate their nature on the receipt which has to be signed by the driver.

Once the equipment is unpacked check to see if it has suffered any damage. Also check that any parts which are delivered unattached to the equipment are present. If there has been any damage to the equipment and/or any parts are missing do not forget that the transport company will accept complaints only up to 15 days from the delivery day and that dr. Zanolli S.r.l. will not be held liable for damage suffered to its products during transit. We are nevertheless willing to help you in presenting your complaint.

⚠ If there is any damage do not attempt to use the equipment and call upon professionally qualified staff.

4.2.Choice of place to install the oven

The good, safe and long working of the equipment also depends on the place in which it is installed so it is advisable to carefully evaluate this before it is delivered.

Install the equipment in a dry place which is easily accessible both as regards its use and its cleaning and maintenance. The area around the equipment must be free of encumbrances. In particular it is necessary to avoid obstructing the cooling apertures.(Figure 5.1).

The equipment must in any case be installed at least 2 cm from the walls of the room and from other equipment.

⚠ Finally it is necessary to ensure that the temperature and relative humidity of the place in which the equipment is installed must never exceed the maximum and minimum values indicated in the specifications section (see 3). In particular if the maximum temperature and relative humidity are exceeded, the equipment may easily and unpredictably go out of order or be damaged in its electrical parts, thus creating a dangerous situation.

4.3.Electrical connection

⚠ Zanolli equipment is supplied with a cable for the electrical connection with earth lead. In observance of the current safety norms **it is compulsory to connect the earth wire (yellow-green) to an equipotential system whose efficiency must be properly checked against the norms currently in force.**

⚠ Before making any connections ensure that the characteristics of the mains supply to which the equipment has to be connected, correspond to the feed characteristics required by the equipment itself (see 3 and plate on equipment).

INSTALLATION WARNINGS

See figure 5-3 for the exact position of the feed cable output.

The feed cable must end in a plug which connects to an electrical feed panel with a corresponding socket and a differential magneto thermal switch.

The plug-socket connection must be such that the earth lead is connected first and disconnected last and must be of the correct size for the nominal current (see 3). Suitable plugs and the industrial type CEE 17 of any which satisfy the European Norm EN 60309.

The thermal safety device must be set for the total nominal current, the magnetic safety device must be set for the instantaneous maximum current (in the case of ovens it is a little above the nominal figure, in the case of machines it is the pick up current for the most powerful motor) , while the differential device must be set to the 30 mA current (see 3.) .

dr. Zanolli S.r.l. shall not be liable for any damage which results from failure to observe the above mentioned norms.

5.INSTALLATION

5.1.Check list

There are no separately supplied parts.

5.2.Choice of the place of installation of the oven

Avoid obstructions to the cooling opening located on the right side of the module (Figure 5.1.).

In choosing the place to install the single deck CIT 6 Modular and CIT 9 Modular bear in mind they have to be completed with the addition of other modules from the series (Hood, prover etc.).

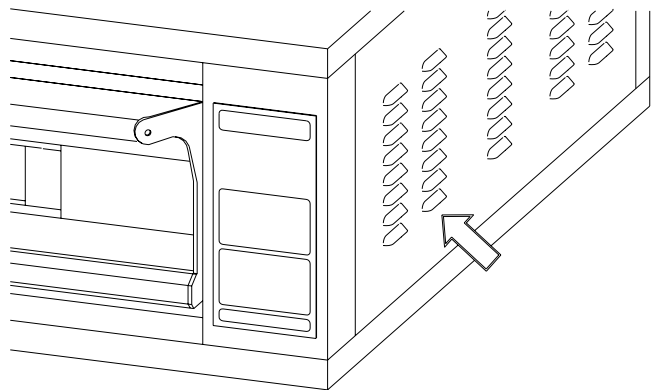

Figure 5.1.Cooling openings

5.3.Moving the module

When unloading and moving the module when it is packed use a fork-lift truck or transpallet which has a capacity at least equal to the weight of the module and insert the forks into the space provided in the lower part of the packing.

When moving the module which is not packed insert the forks in the upper chamber.

It is also possible to transport the module by means of the two hooks which are accessible from the two openings in the top part.

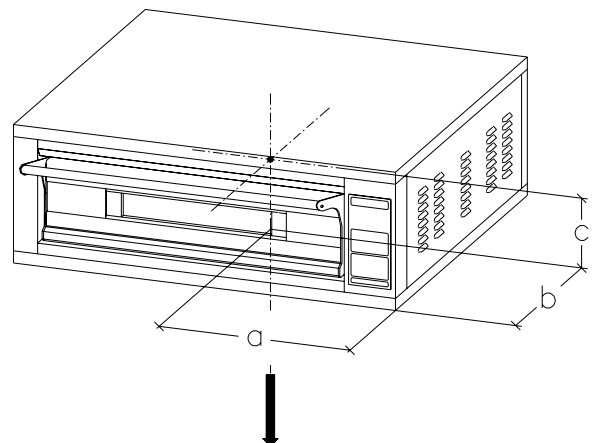

Figure 5.2.Centre of gravity

INSTALLATION

⚠ In any case, to avoid unforeseen movements, take note of the position of the centre of gravity (Figure 5.2.and table.5.1.).

⊘ In addition, to avoid damage to the module, insert some protective material between the forks and the module itself.

	a mm	b mm	c mm
CIT 6 Mod.	685	455	200
CIT 9 Mod.	685	630	200

Table 5.1. Centre of gravity

5.4. Mounting the module

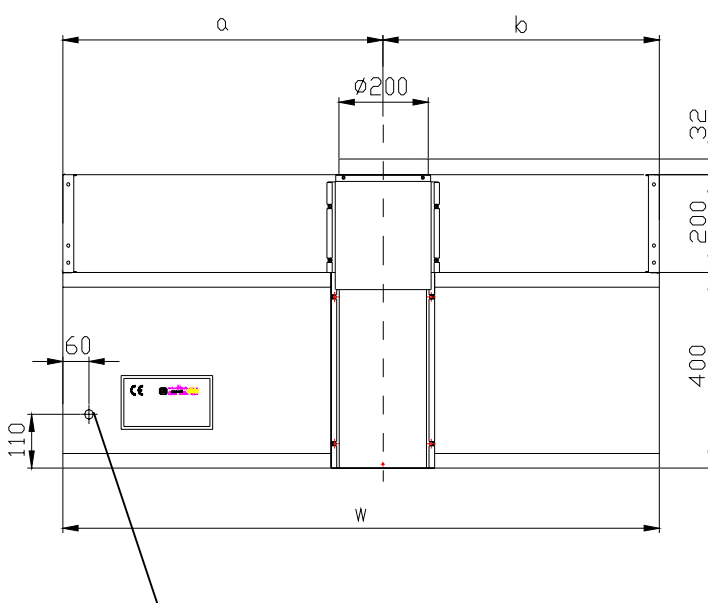

Ingresso cavo elettrico

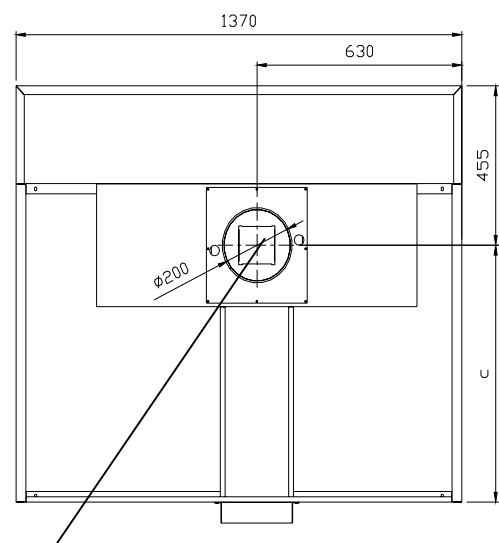

Scarico vapori

	a mm	b mm	c mm	w mm
CIT 6 Mod.	740	630	733	1370
CIT 9 Mod.	740	630	1083	1370

Figure 5.3. Position of electrical cable input, steam outlet and plate.

Position the modules one above the other in the right order (prover or base, baking module, hood) and fix by means of the accompanying hooks and screws.

5.5. Connecting the steam outlet

The steam outlet should be connected through the duct on the hood (see instructions). It is necessary to use a pipe Ø200 mm connected to the outside.

⊘ Avoid long horizontal stretches as they may lead to accumulations of condensation and possible dripping.
For the exact connection position see Figure 5-3.

5.6. Checks before starting up

Turn on the main switch on the switchboard.

Turn on the  switch (6.1.2.), program a temperature above 200 °C (6.2.3.), set both the power regulators at 10.

Check that the current to each phase is that indicated in chapter 3., for the corresponding feed voltage.

Set both the power regulators at 5 and check that their lights go on and off at intervals.

Turn off the switches  and the main switch on the board.

IMPORTANTE - PRIMER ENCENDIDO

Los componentes del horno recién adquirido (planos de cocción en refractario y chapa metálica) necesitan una fase de precalentamiento.

LLEVAR GRADUALMENTE EL HORNO A TEMPERATURA EN UN ARCO DE 5-6 HORAS; con ocasión del primer encendido, es un procedimiento INDISPENSABLE para evitar eventuales daños de dichas partes (cuando se alcanzan las máximas temperaturas en las primeras horas de funcionamiento).

6.WORKING

6.1 Control panel

Figure 7.1. shows the control panel with all controls:

6.1.1.Temperature control

 Baking chamber temperature display

 Set button

 Up button

 Down button

out  Out display

6.1.2.General

 Baking chamber light switch

 Baking chamber on/off switch

 Light switch for suction hood

6.1.3.Power control

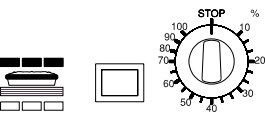
 Oven roof power regulator and light

 Oven bedplate power regulator and light

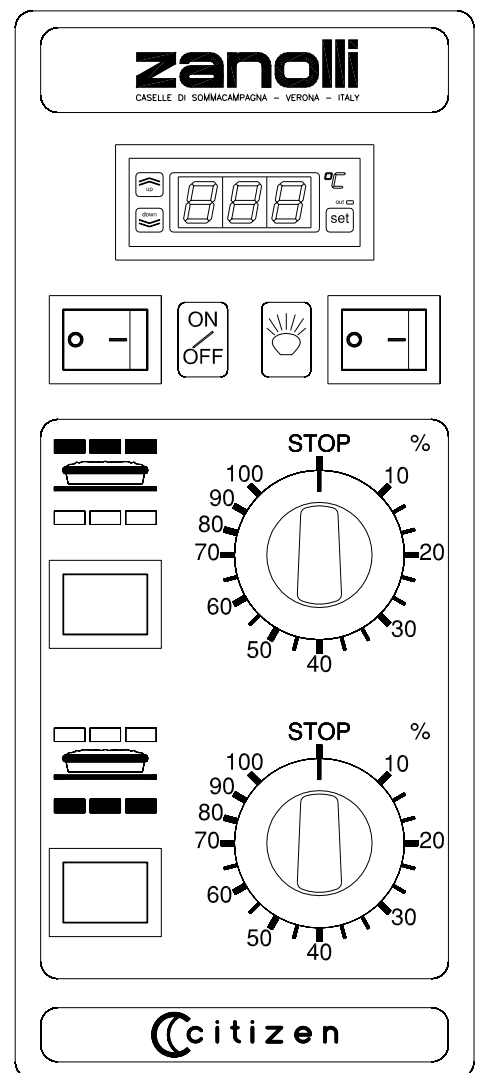



Fig.7.1.Control panel

6.2. Control description

6.2.1. Main ON/OFF switch

When this switch is OFF, all displays on the control panel are off. When it is ON, the switch itself and the thermostat turn on, so that it is possible to set the temperature. The baking chamber heating elements remain off as long as the  switch is off. When the switch is ON, it turns on and the baking chamber heating elements turn on according to the set temperature and power.

6.2.2. Baking chamber light switch

By setting switch on ON, the switch and the chamber light turn on.

6.2.3. Light switch for suction hood

The light switch for suction hood control is placed on the side part of the control panel, on the upper side (Pos.1 of Fig. 7.2). Push this switch on position 1 to start the suction hood. Push this switch on position 0 to stop it.

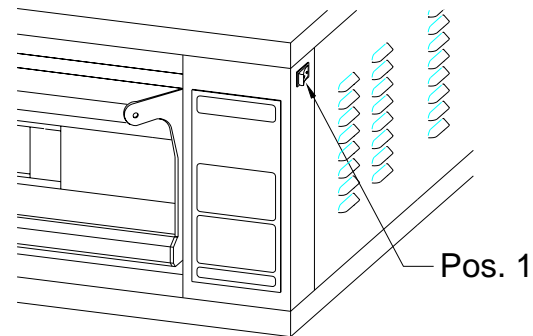

Fig.7.2

6.2.4. Temperature control Baking chamber temperature display



In the normal operation mode, this display shows the cooking chamber temperature in °C.

In the temperature programming mode, this display shows the programmed temperature. This display is also used to display some failures. (6.3.) .

6.2.5.  **Set button,**  **Push-button of ESC.**

Press two times this button to select the temperature programming mode.

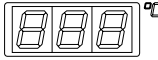
⊘ **WARNING !** do not keep this button pressed because this might alter the thermostat internal parameters and cause possible unpredictable failures.

In this operation mode, the  display shows the programmed temperature, which can be changed using the 

and  buttons. If no buttons are pressed for more than 3 seconds, the thermostat automatically returns to the normal operation mode. See chapter 3 for the range of temperatures that can be selected.

To press two times this push-button  in order to exit from the way programming temperature.

6.2.6.  and  **buttons**

By pressing and releasing these buttons once, the set temperature increases or decreases by one unit. By keeping them pressed, the set temperature increases or decreases progressively, slowly at first and then faster.

6.2.7. **OUT display**

The  display turns on every time the baking chamber temperature is below the set temperature. It turns off when the cooking chamber temperature reaches the set temperature and goes on again when the baking chamber temperature goes 1° C below the set temperature.

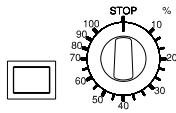

When the  display is on, the baking chamber heating elements turn on according to their power settings.

6.2.8. **Power regulators**



Each baking chamber has two power regulators, one connected to the oven roof heating elements, and the other one to the bedplate heating elements. These regulators ensure an even distribution of the heat inside the baking chamber so as to obtain an even cooking.

Each power regulator controls the power of its own heating element, regulating the start up time of the heating element within a range of 30 seconds.

If the power regulator is set on 1, its heating element will be on for 3 seconds and off for 27 seconds (provided the  is on). If the power regulator is placed on 5, its heating element is on for 15 seconds and off for 15 seconds. When the power regulator is placed on 10 , its heating element is always on (provided the  display is on).

6.2.9. **Oven roof and bedplate pilot lamps**

Both oven roof and bedplate pilot lamps turn on when the  display is on and its power regulator is switching on within the regulation cycle, to indicate that its heating element is actually on.

power regulation		
position	no. secs. to switch on	no. secs. to switch off
1	3	27
2	6	24
3	9	21
4	12	18
5	15	15
6	18	12
7	21	9
8	24	6
9	27	3
10	30	0

6.3.Error display

6.3.1.Short-circuited thermocouple

When the thermocouple is across the line (short circuit), the

 °C display shows “---”.

6.3.2.Disconnected thermocouple

When the thermocouple is disconnected or interrupted, the

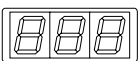
 °C display shows “EEE”.

The same code of error appears if the baking chamber temperature exceeds the maximum temperature that can be selected.

7.USE



7.1.Preparation for use



 If the equipment has just been installed or has not been used for a number of days, before using it for food products, it is necessary to clean it thoroughly in accordance with the indications in chapter 8 to remove residual factory dirt, accumulations of dust or any other substances which could contaminate food products.

7.2.Switching on the control panel

Turn on the  light switch: the control panel comes on and settings can be made while the baking chamber is still off.

7.3.Setting



Set the required temperature using the ,  and  buttons (see 6.2.3.).

Set the power of the heating elements for the oven roof  and bedplate with the switch .

7.4.Starting baking

At this stage switch on the  switch : after a short time you will see that the temperature in the baking chamber starts to rise. If you have set the maximum temperature the oven will reach this in 40-45 minutes.

7.5. Loading the oven

 **WARNING:** when the chamber is at its working temperature, the glass and metal parts of the door and some of the surrounding sections reach temperatures which are dangerous for the human body. These parts are identified with the symbol , which warns of this risk.

7.6. General indications for good cooking

It is not possible to say exact times and temperatures for food products in general given the enormous variations they are subject to.

As regards in particular pizzas and similar products, the cooking time and the temperature depend on the shape and thickness of the dough and the quantities of the ingredients added to it. We therefore advise that a few test runs are made, especially if you have never worked with this model of oven before, starting out with a temperature of 250-300°C and bearing in mind the following points:

- 1) generally with lower temperatures a better quality and more digestible product is obtained, the oven is not subjected to particular stresses and lasts longer, though the cooking times become longer.
- 2) with higher temperatures it is more difficult to obtain even cooking but the cooking times are reduced.
- 3) just after loading the oven it is normal for there to be a fall in the temperature of the oven of as much as 20-30 °C . This should not be considered a limitation of the oven but as a useful indication that at the beginning of cooking the water in the raw dough is evaporating and taking up a large quantity of heat. It is, however, always possible to set a higher temperature so that the oven reaches the desired temperature on loading. In any case if the oven

is used within the limits of its maximum capacity, the temperature will start to rise again towards the end of the cooking time.

4) the oven has a maximum production capacity expressed **indicatively** in the characteristics in Kg of product per hour (chapter 3.). If this production capacity is exceeded, the temperature of the baking chamber will fall even beyond 20-30°C. In such a case the excess quantity should be removed and you should wait until the desired temperature has returned before any further loading.

5) if you keep the steam outlet valve completely closed, the steam comes out under the loading door and the products (in particular in the case of pizzas) may remain too moist. If you open the valve completely, the products dry out too much and the oven has a lower yield. When cooking pizzas you should therefore try opening the valve to a third.

7.7.Switching off

At the end of each working day turn off the  switch .

During long periods of idleness (e.g. closures for holidays) it is advisable to switch off the main switch on the electrical feed panel.

8.CLEANING

⚠ At the end of each working day (or more frequently if possible) it is necessary to carefully clean the cooking surface and all the parts of the oven which come into contact with the food being cooked to avoid that any food substances go off and contaminate either the working environment or later products to be cooked.

⚠ Cleaning should be carried out with the equipment switched off and at room temperature and after having switched off its electrical supply using the button on the feed panel.

8.1.Cleaning of any visible glass and stainless steel parts

⚠ Glass is particularly sensitive to sudden changes in temperature which can cause it to shatter into fragments. **Do not handle the glass or bring it into contact with water until it is at room temperature.**

⊘ It is also not advisable to use abrasives (abrasive sponges and such like) as they may in the long term diminish the shine of stainless steel parts and of glass. It is better to wash the various removable parts before the food residues are dry.

8.2.Cleaning of any refractory parts

Use a brush to remove cooking residues from the refractory surfaces in the ovens. If there are any residues stuck to the refractory surfaces, remove them carefully with a spatula.

⚠ Do not use any liquids, especially detergents, since the refractory material is porous and it is not possible to rinse it to ensure it is not contaminated by foods in contact with these surfaces.

⊘ You should also not use cleaning instruments which are too abrasive as the refractory material is fragile and could easily get chipped or even break.

8.3.Cleaning the oven's baking chamber

Use a soft damp sponge to clean the stainless steel or aluminium plate baking chamber, if necessary with a light, non abrasive detergent, being careful that it does not splash onto any refractory surfaces.

If there are substantial deposit of grease or fat, remove them carefully beforehand with a spatula.

⊘ Do not use abrasive detergents or corrosive materials as they could dull the stainless steel and would quickly remove the aluminium-coated steel's protective layer, causing it to become rusty in a short time.

⚠ Do not use jets of water as they could penetrate the switchboard and damage to create a danger of electrocution and/or sudden ups of the equipment.

8.4.Cleaning the external surface

Use a soft damp sponge to clean, if necessary with a light non abrasive detergent, the external surfaces made of stainless steel and/or coated steel.

⊘ Do not use abrasive detergents or corrosives as they could cause the stainless steel and the coatings to become dull in the long term, and thus cause the steel sheets to become rusty.

⚠ Do not use jets of water as they could penetrate the switchboard and damage to create a danger of electrocution and/or sudden start ups of the equipment.

9. MAINTENANCE

⚠ WARNING: These use and maintenance instructions are intended only for staff which is qualified for the installation and maintenance of electrical and gas equipment. Maintenance by other persons may cause damage to the equipment, persons, animals or things.

⚠ In the majority of cases it is necessary to remove the fixed guards in order to carry out repairs and checks. This also renders the voltage cables accessible. **Before carrying out any maintenance operations, check that the equipment's feed cable plug is disconnected from the switchboard. Put the plug in a place where the maintenance operator can easily ascertain, during all of the work done with the guards removed, that it has been disconnected.**

9.1. Ordinary maintenance work

9.1.1. Light replacement

Disconnect the plug from the electrical feed panel.

⚠ The light is located in a part of the oven which has no heat insulation. This means that the external closing of that space reaches high temperatures when the oven is working. **The light replacement should therefore be carried out only when the oven is cold, or using protective gloves.**

Unscrew the screws which attach the light holder supports to the wall of the oven and remove the external door to the light space. Since the lamp holder is fixed to this door, be careful not to jerk the electrical wires.

The light bulb should be replaced with one of equal power (75 W) and made to resist high temperatures.

Remount the light door being careful the wires are in the right position.

9.2. Error displays

The electronic control is able to detect some failures, for details see 6.3.

9.3. Electrical diagram

Figures 10-1, 10-2, 10-3, 10-4, 10-5, 10-6 shows the electrical diagrams of the Citizen series: 6 Modular e 9 Modular for the 400Vac 3-N, 230Vac 3 and 230Vac 1-N versions.

9.4. Adjustment for different feed voltages

 **Warning!** To adapt the equipment to work at different feed voltages from that indicated on the initial set up label, three alterations have to be made:

- 1) to the cabling for the resistor wires.
- 2) to the cabling for the feed to the control panel.
- 3) to the application of a new label.

Carry out three alterations with care as otherwise the equipment may be unsafe.

9.4.1. Cabling of wires to the resistor

Disconnect the plug from the electrical feed panel. Remove the guard from the switchboard and disconnect all the wires from the remote-control switches' resistors and reconnect them as shown in Figure 10-1, 10-2, 10-3, 10-4, 10-5, 10-6 depending on the voltage.

9.4.2.The cabling for the feed to the control panel

Detach the BLUE wire from the lower remote-control switch and reconnect it as shown in Figure 10-1, 10-2, 10-3, 10-4, 10-5, 10-6 depending on the voltage.

9.4.3.Attachment of new label

Stick an indelible badge with the new setting data, under the serial number plate (Figure 5.3).

9.5.Exploded views and spare parts list

Please contact us if more complex work has to be done or if there are broken parts. In any case, in order to simplify the search for the causes of breakdowns and any replacement of damaged parts, we give below a list of spare parts and exploded views which show each of the listed parts.

The exploded views Figure 10-7,10-8 e T_{AB}10.1 refer to the baking module CIT 6 Modular, but the indications are also valid for the other versions.

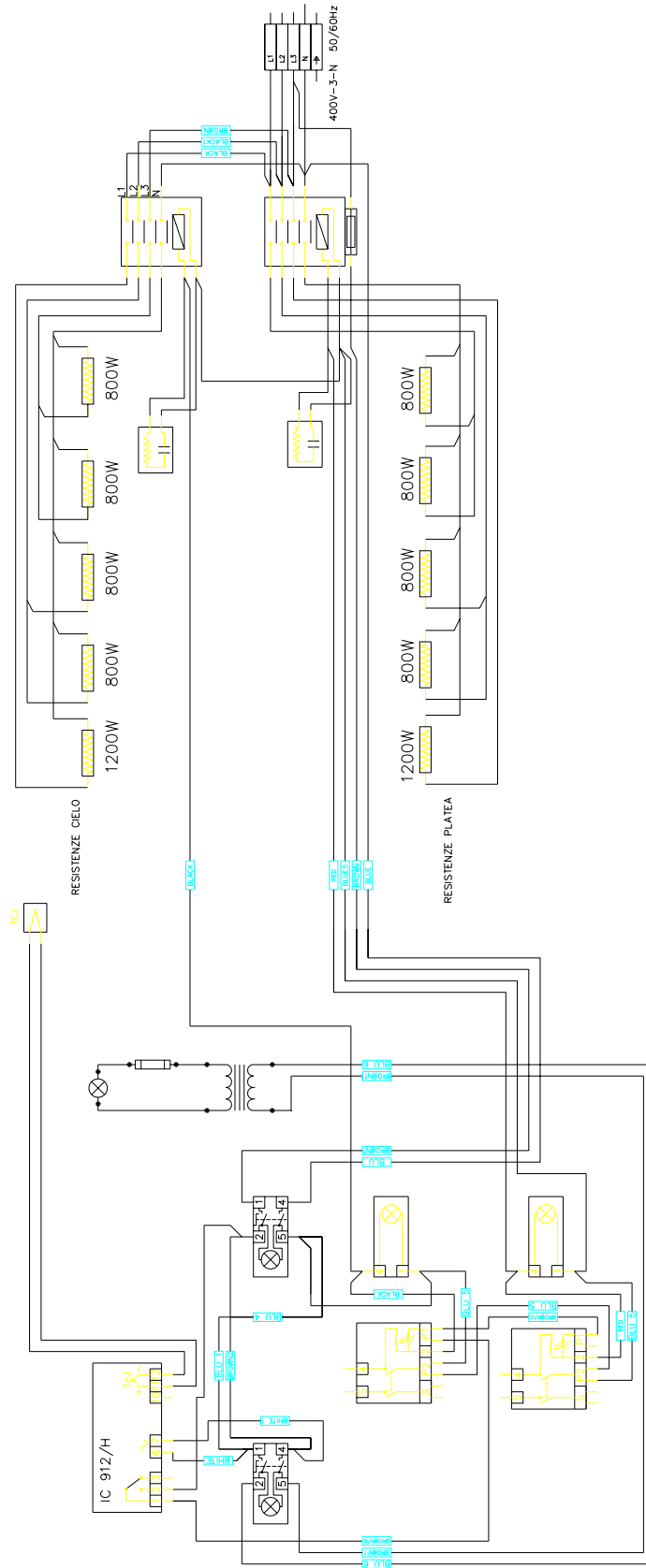

Figure 10-1. Electrical diagram for CIT 6 Modular at 400 Vac. 3-N version.

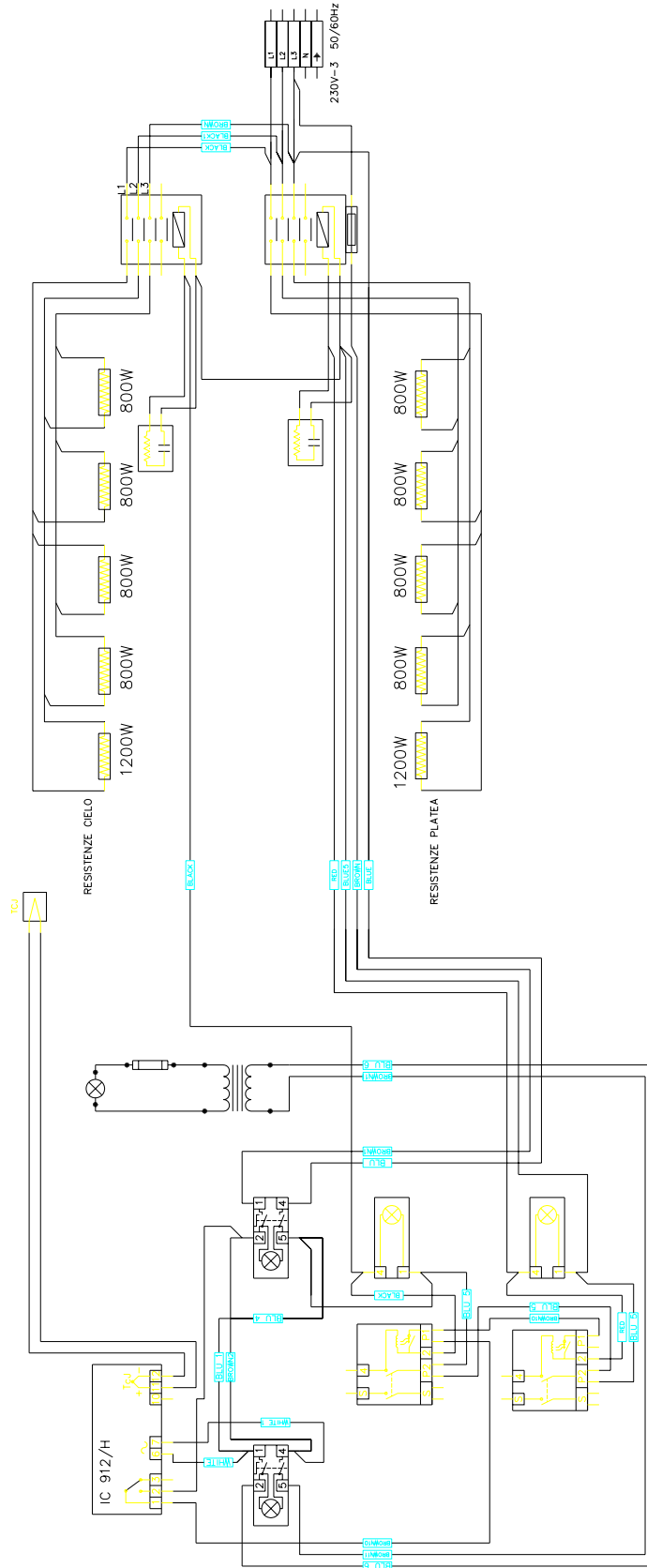

Figure 10-2. Electrical diagram for CIT 6 Modular at 230 Vac. 3 version.

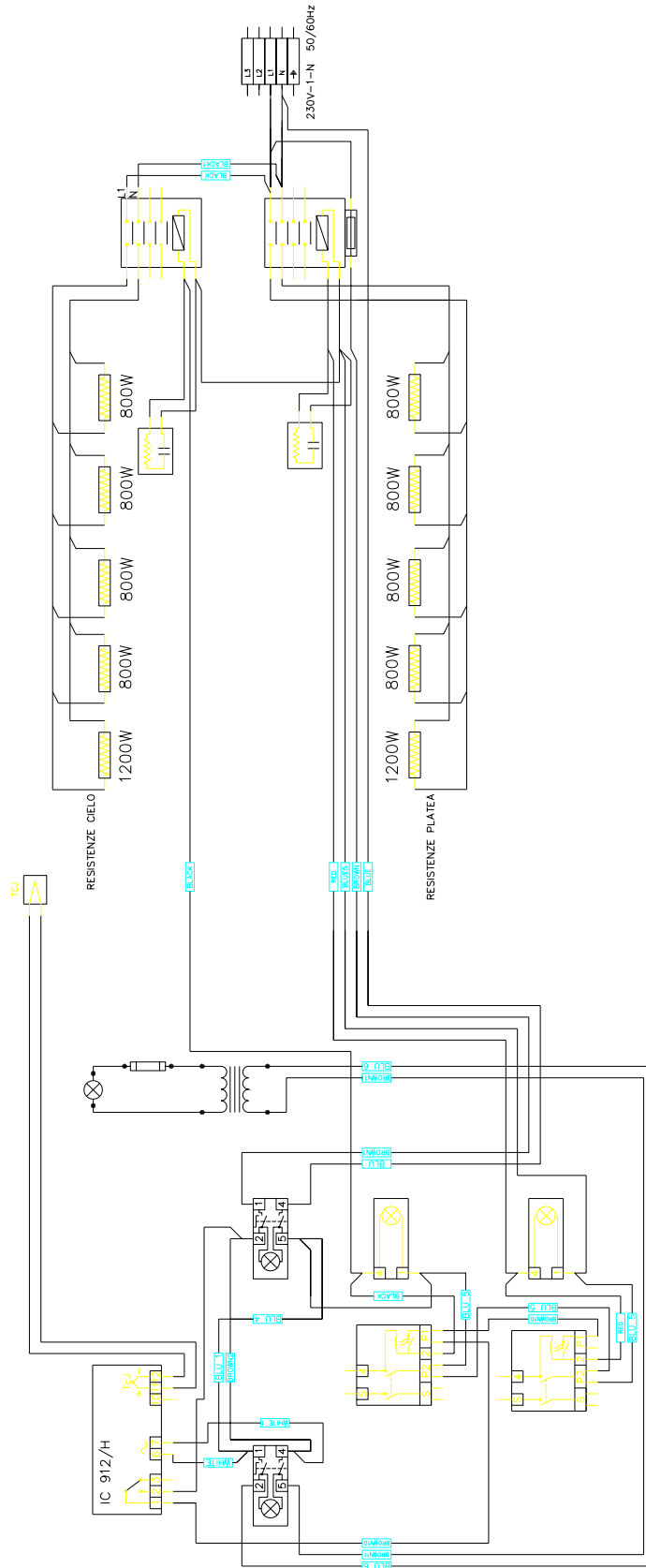

Figure 10-3. Electrical diagram for CIT 6 Modular at 230 Vac. 1-N version.

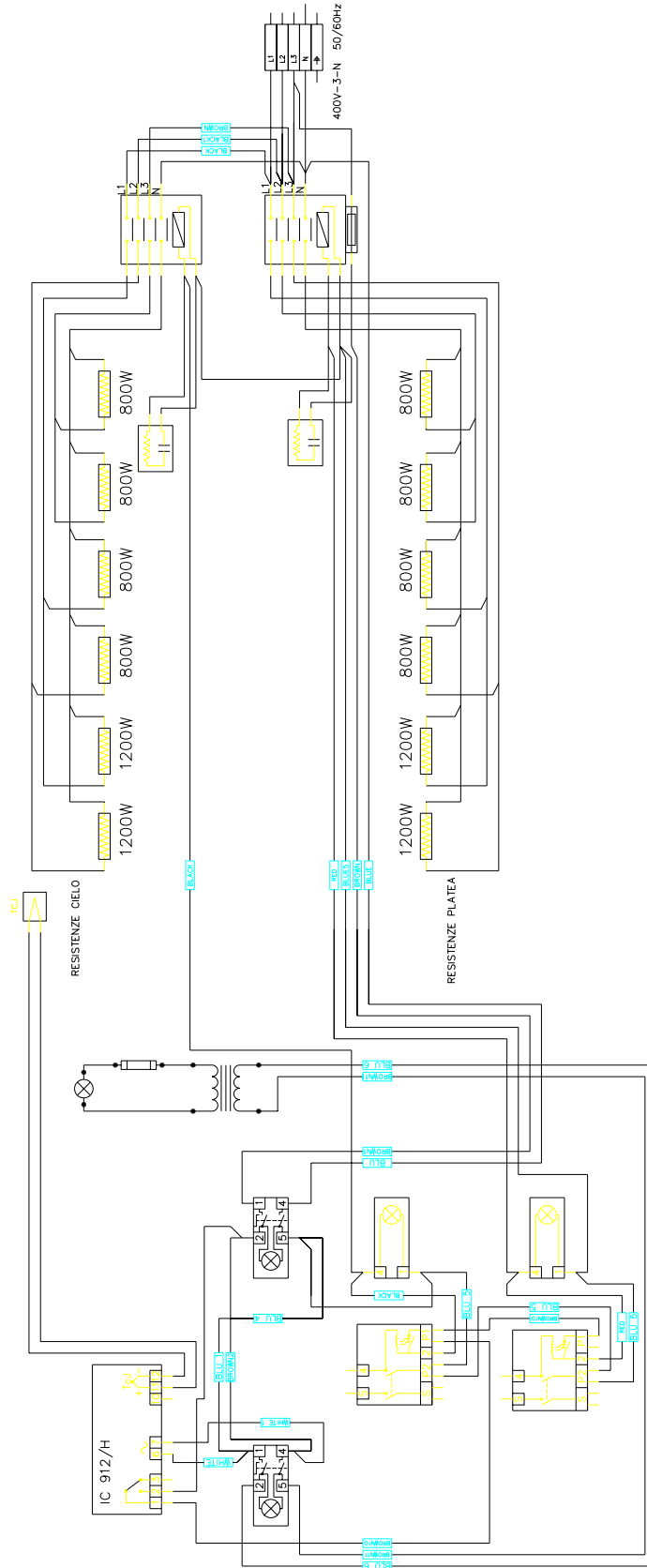

Figure 10-4. Electrical diagram for CIT 9 Modular at 400 Vac. 3-N version.

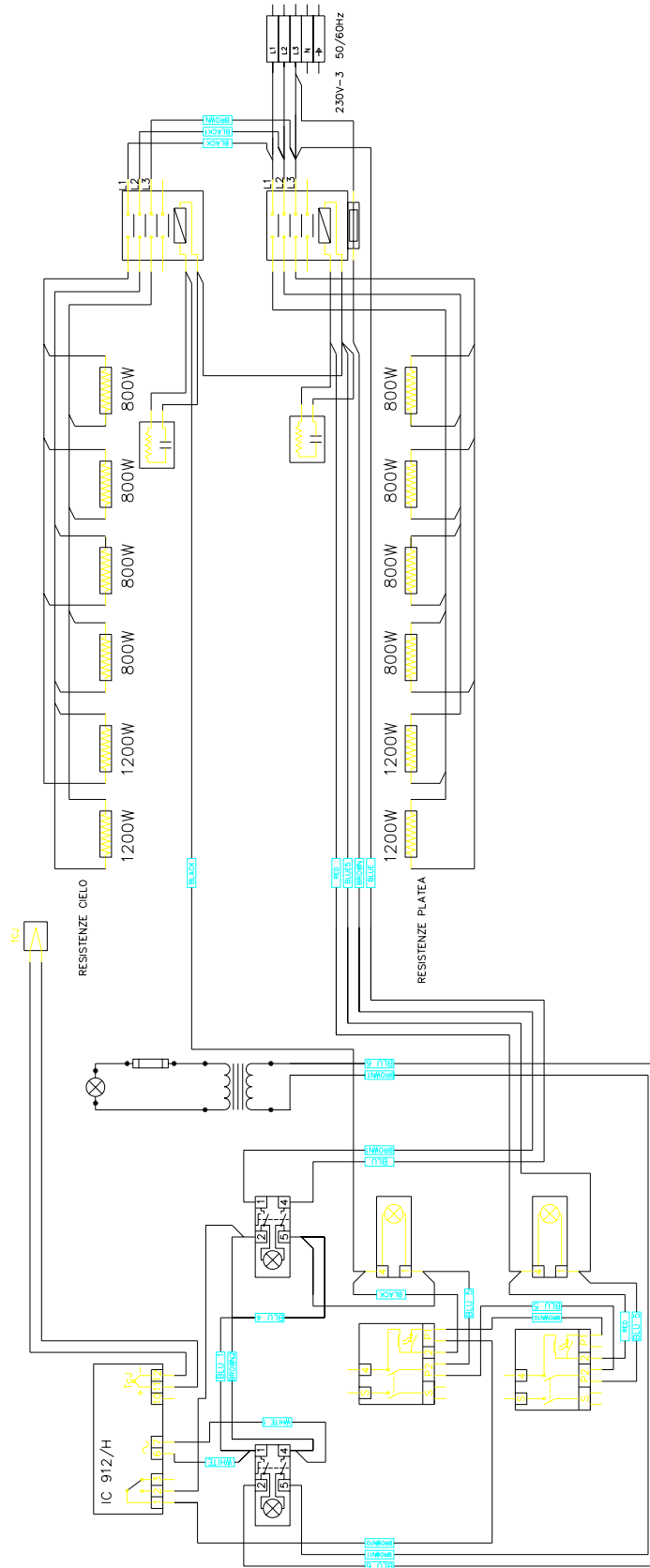

Figure 10-5. Electrical diagram for CIT 9 Modular at 230 Vac. 3 version.

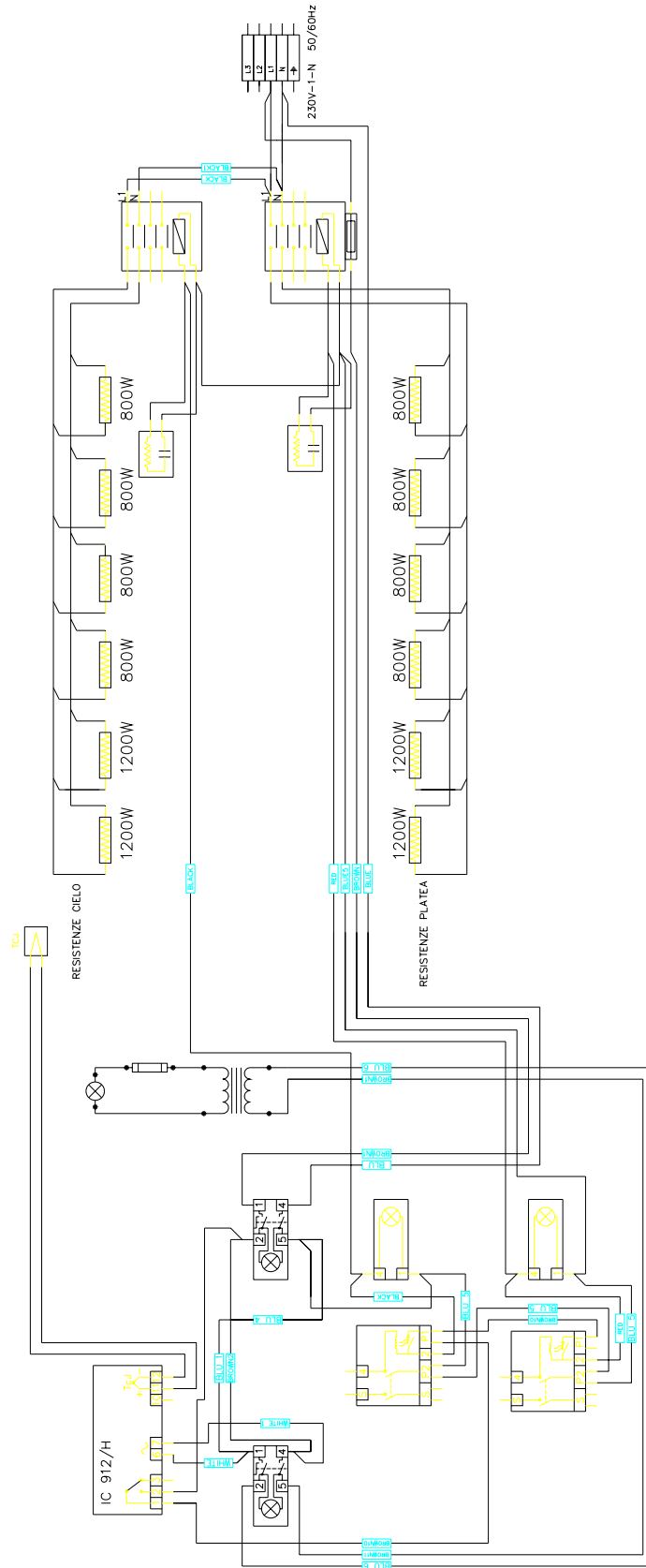

Figure 10-6. Electrical diagram for CIT 9 Modular at 230 Vac. 1-N version.

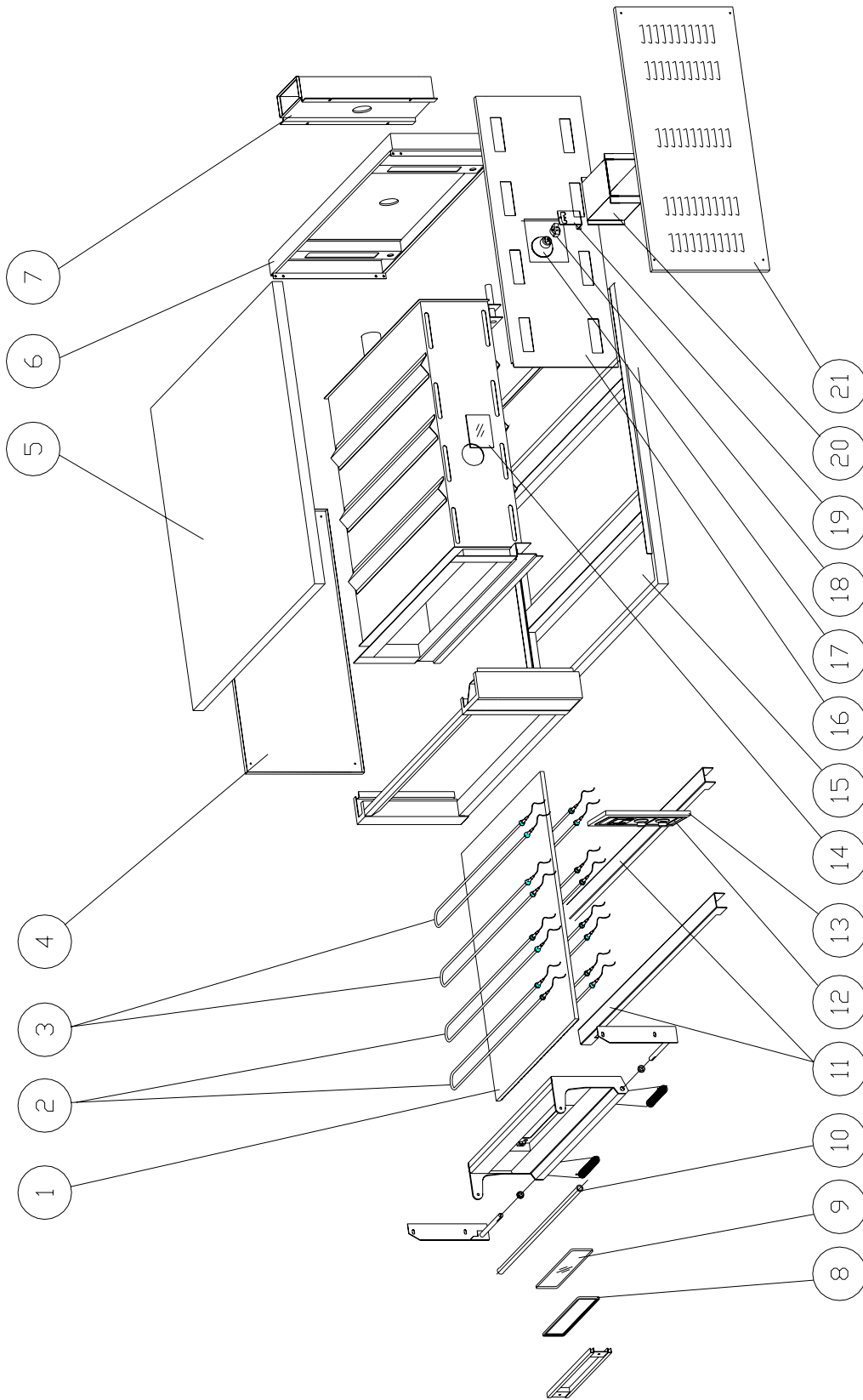

Figure 10-7 Exploded view

MAINTENANCE

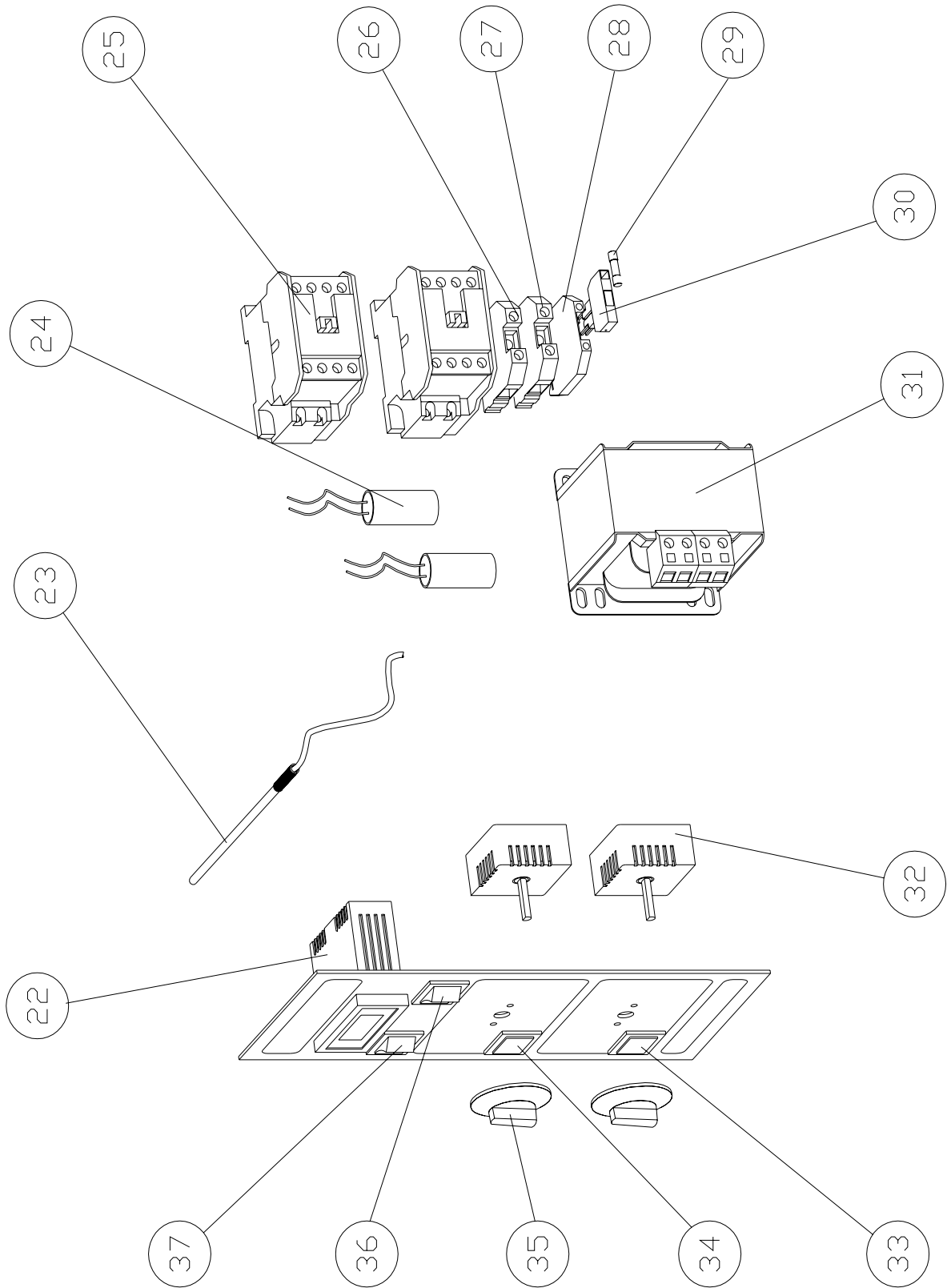

Figure 10-8 Exploded view of electrical parts

MAINTENANCE

N°.	Description	Codes	
		CIT. 6 Modular (105X70)	CIT. 9 Modular (105X105)
1	REFRACTORY SURFACE	REFR0035	REFR0034
2	FRONT HEATING ELEMENT	RESI0077	RESI0077
3	REAR HEATING ELEMENT	RESI0078	RESI0078
4	LEFT GUARD	FIAN0201	FIAN0199
5	TOP PANEL	CARP0640	CARP0576
6	REAR PANEL	FIAN0206	FIAN0206
7	FLUE	TUBO0074	TUBO0074
8	DOOR GLASS SEAL	GUAR0010	GUAR0010
9	DOOR GLASS	CRIS0028	CRIS0028
10	HANDLE	MANI0063	MANI0063
11	REFRACTORY BRACE	CARP1212	CARP1212
12	CONTROL PANEL	PANN0135	PANN0135
13	CONTROL PANEL MOUNT	CART0123	CART0123
14	LIGHT HOUSING GLASS	CRIS0027	CRIS0027
15	BOTTOM PANEL	CARP0639	CARP0575
16	RESTRINING PANEL	CARP0641	CARP0583
17	HALOGEN LAMP	LAMP0020	LAMP0020
18	HALOGEN LAMP MOUNT	LAMP0021	LAMP0021
19	HOLDER	CARP1276	CARP1276
20	LAMP COLDIND BOX	CARP0581	CARP0581
21	RIGHT GUARD	FIAN0202	FIAN0200
22	THERMOSTAT	TERM0012	TERM0012
23	PROBE	TERM0020	TERM0020
24	CONTROL SWITCH	ELET0002	ELET0002
25	ANTI JAMMING DEVICE	ELET0116	ELET0116
26	FUSE PORT 16 MMQ OR FUSE PORT 35 MMQ	ELET0235	ELET0235
		ELET0049	ELET0049
27	EARTH PORT 16 MMQ OR EARTH PORT 35 MMQ	ELET0236	ELET0236
		ELET0054	ELET0054
28	FUSE HOLDER PORT	ELET0058	ELET0058
29	FUSE	ELET0204	ELET0204
30	FUSE HOLDER	ELET0040	ELET0040
31	LAMP TRANSFORM	ELET0144	ELET0144
32	ENERGY REGULATOR	TERM0014	TERM0014
33	GREEN PILOT LAMP	LAMP0006	LAMP0006
34	ORANGE PILOT LAMP	LAMP0002	LAMP0002
35	KNOB	MANI0021	MANI0021
36	ORANGE SWITCH	INTE0009	INTE0009
37	GREEN SWITCH	INTE0010	INTE0010

Tab.10.1.List of spare parts

10.DECOMMISSIONING AND DEMOLITION

Before proceeding with the decommissioning disconnect the electrical supplies to the equipment and any other connections there may be and then move the machines using suitable means such as : forklift trucks, hoists, etc..... keeping in mind the position of the centres of gravity (see table 5.1.) indicated in the chapter INSTALLATION (5). The machines are made up of the following materials: stainless steel, coated steel sheets, plastic material, and electrical parts. For the purposes of demolition therefore the materials have to be separated in observance with the norms in force in the place where machine is being dismantled. In any case do not dispose of into the environment.

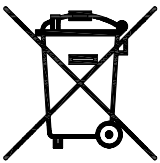

Separate collection. This product must not be disposed of with normal household waste. Local regulations may provide for separate collection of this kind of product.